

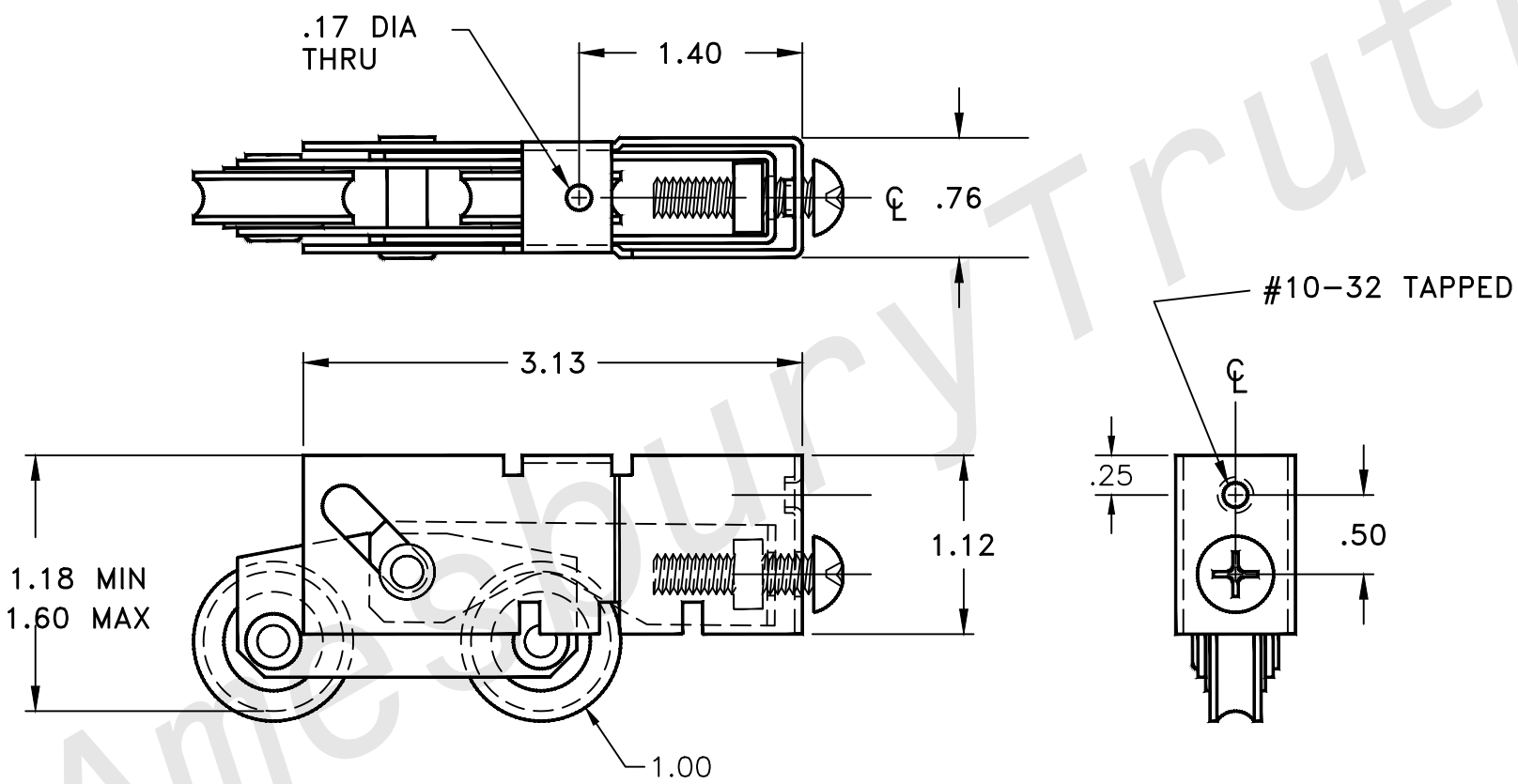

| | | | | |
|------|-------------|-----|-------|----|
| DATE | DESCRIPTION | REV | ECN # | BY |
|------|-------------|-----|-------|----|



CUSTOMER PAGE

| | | | | |
|--|------------------|---|---|----------|
| <p>The information contained in this drawing is confidential and proprietary. This drawing is not to be copied or reproduced in whole or in part without express written permission. The information contained in this drawing is not to be disclosed or used in the performance of services or manufacture of goods for any other party without express written permission.</p> | DRAWN: | INTERPRET PER: ASME Y14.5M-1994 | DRAWING TITLE: | |
| | DATE: 2/22/22 | UNITS: INCH | TA-36-BS-100-C2 | |
| | | THIRD ANGLE PROJECTION |  | |
| | |  | PART #: 1936-2000-210 | REV A |
| | | Engineered Solutions. Trusted Results. | SCALE: | SHEET OF |